

Tandem Vibratory Roller

BW90AD-2



EARTHWORKS						
# passes	rolling speed	area coverage sq yd/hr	"productivity in cu yd/hr by lift thickness, 100% efficiency"			
	(mph)		4 inches	6 inches	8 inches	12 inches
2	2.8	2423	270	404	539	809
3	2.8	1615	180	270	359	539
4	2.8	1211	135	202	270	404
5	2.8	969	108	162	216	324

ASPHALTIC CONCRETE (material weight 140 lb/cu ft)						
# passes	rolling speed	area coverage sq yd/hr	"productivity in tons/hr by lift thickness, 100% efficiency"			
	(mph)		1.5 inches	2 inches	2.5 inches	3 inches
2	2.8	2423	191	255	318	382
3	2.8	1615	127	170	212	255
4	2.8	1211	96	127	159	191
5	2.8	969	76	102	127	153
6	2.8	808	64	85	106	127

Note: Repeat number of passes over the same area is required to achieve specified compaction efficiency/density. Successive passes over same area results in reduced area coverage and productivity. Rolling speed selected provides impact spacing of a minimum 10 impacts per foot at high vibration frequency setting. Actual compaction efficiency is determined by job conditions.



BW90AD-2

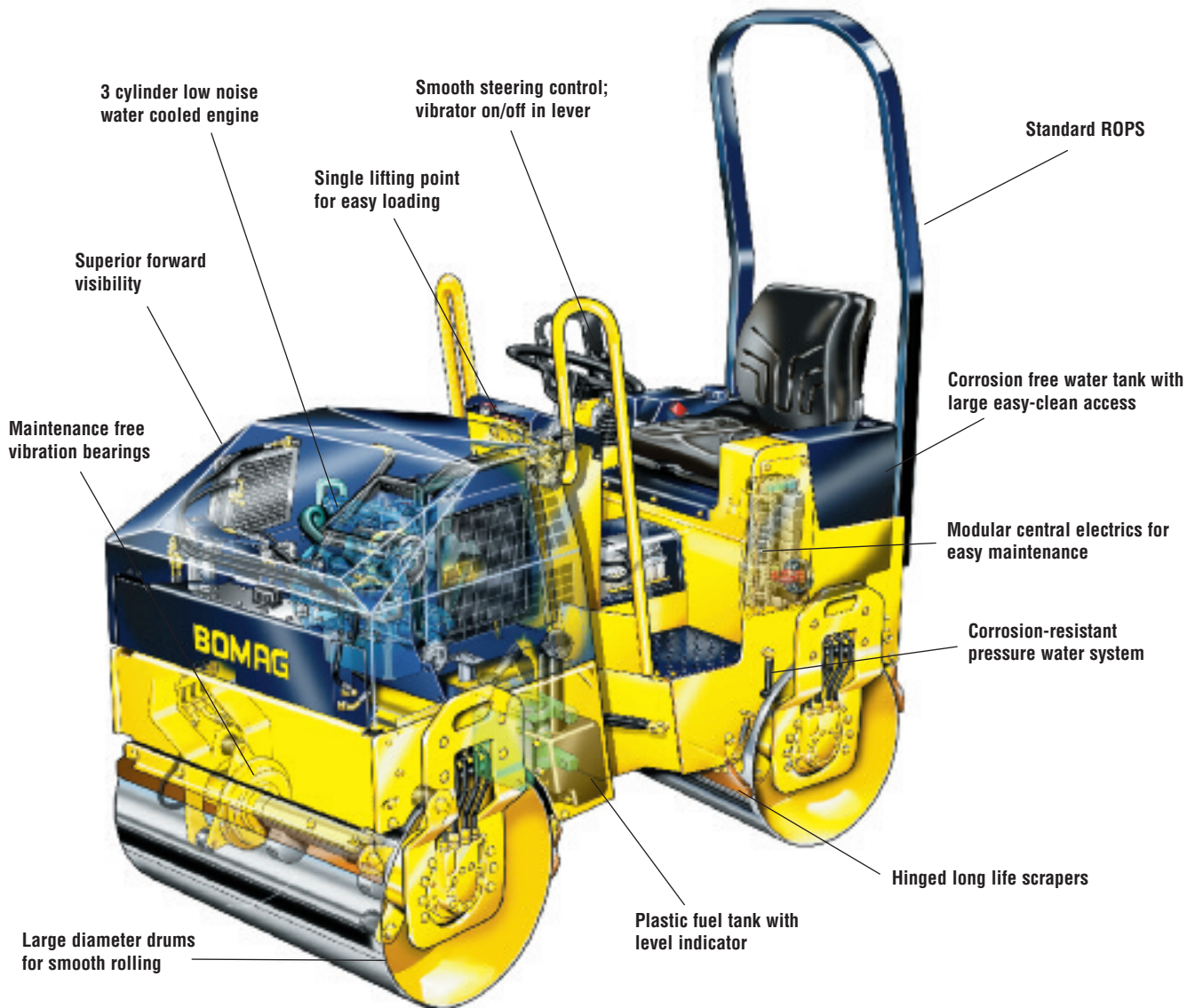

■ *BW90AD-2 - designed for today's contractor...*

Compact size, high maneuverability and heavy roller features describe the BW90AD-2 tandem vibratory roller. Integrated design concepts such as tight inside turning radius, minimal lateral overhang and unobstructed view of drum edges make the BW90AD-2 perfect for high productivity in confined areas. Large diameter drums having optimum frequency, amplitude and resultant centrifugal force(s) further enhance operator and roller productivity.

■ Applications:

- Granular sub-base compaction
- Walkways, bicycle and cart paths
- Driveways
- Parking lots
- Road rehabilitation and patching



BW90AD-2 in action on an asphalt repair

Featuring...



Controls ensure simple and easy operation

■ Handling Easier & Safer:

- The drum edges are clearly visible at all times for excellent maneuverability even in confined areas.
- Ergonomic arrangement of controls ensures simple and easy operation even for inexperienced operators.
- The operator's platform has ample leg room for fatigue-free work.
- Travel lever with integrated vibration control provides sensitive operation.
- Rear drum vibration can be switched off for the compaction of thin lifts.
- Lockable dashboard cover protects controls from vandalism.
- The corrosion-resistant pressure water spray system features a plastic water tank with a large drain opening for easy rinsing.
- Single point lifting eye and tie-downs provide convenient and safe transportation.

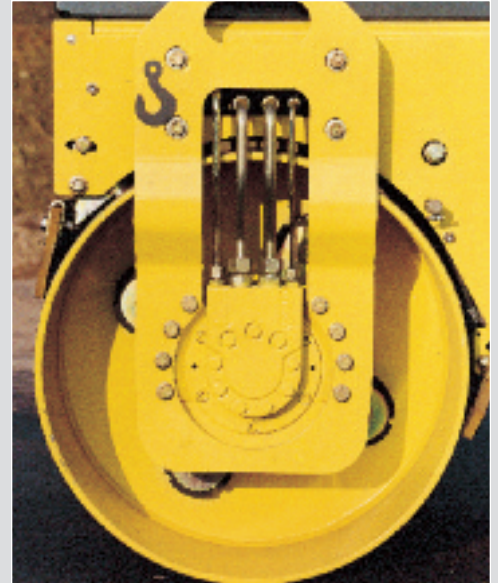

Large diameter drum provides optimum surface finish

Light duty tandem models provide maximum versatility

■ Achieve Maximum Productivity:

- Vibration is automatically shut down if working speeds are too high, minimizing operator error which can result in asphalt ripples and costly rework.
- Large diameter drums reduce pushing and cracking, giving a high-quality finish.
- Frequency and amplitude are matched for high performance on a wide range of applications.
- High curb clearance and minimal lateral overhang help avoid damage when working close to obstructions.
- Corrosion-resistant pressure water spray system with large water tank helps to prevent downtime when laying asphalt.
- Hydraulic pump and motors are plumbed in series to maximize gradeability and traction.

■ Less Service & Maintenance:

The purchase price is important, but so are the operating costs. Check these features:

- The heavy-duty oscillating, articulation joint is firmly bolted on and designed to withstand extreme loads.
- Wide opening, lockable engine cover allows fast servicing and prevents vandalism.
- The BOMAG oil filtration system extends oil and filter change intervals up to 2 years or 2000 operating hours.
- Maintenance-free vibration bearings and SAHR brakes.
- Hydraulic test ports are easily accessible for fast trouble-shooting.
- Daily checks can be quickly carried out with visual checks for hydraulic oil level, oil filter and air filter.
- LED diagnostics for the electrical system provide effective trouble-shooting on-site.
- Corrosion-resistant control boards with fault-finding LEDs ensure reliability and proper operation.



Excellent visibility makes handling easy



All around easy engine access

With these features and many more, it's easy to see why this model maintains a high residual value while delivering lower lifetime operating costs.

Technical Specifications

BW90AD-2

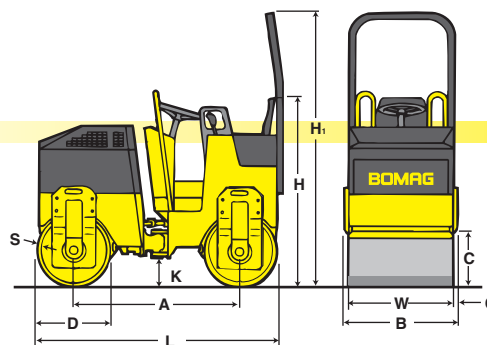

Shipping dimensions

in cubic feet (m³)

without/with ROPS

BW90AD-2

93 (2.6) / 150 (4.3)

Standard Equipment

- Hydrostatic travel and vibration drives
- Bolt-on oscillating/articulation joint
- Hydrostatic articulated steering
- Spring-Applied, Hydraulically-Released (SAHR) parking brakes on each drum
- Vibration control in travel lever
- 2 scrapers per drum
- Plastic water tank
- Pressure sprinkler system with interval timer
- Control and warning indicator lights for:
 - Engine oil pressure
 - Battery
 - Brakes
- Hour meter
- Lockable engine cover
- Vandal protected instrument panel
- Transport lifting points - front, central and rear
- Emergency stop button
- Rear drum vibration lock out
- Corrosion and weather protected ignition switch
- ROPS with seat belt
- Back-up alarm
- Fuel level indicator

Optional Equipment

- Working lights (front & rear)
- Hinged ROPS
- Service Kit

Dimensions in inches (mm)

	A	B	C	D	H	H ₁	K	L	O	S	W
BW90AD-2	50.5	37.6	18	22.8	58.3	90.6	9.8	73.3	1.1	0.5	35.4
	(1282)	(956)	(458)	(580)	(1482)	(2300)	(250)	(1862)	(28)	(12)	(900)

Technical data

Weights

Basic Weight with ROPS	lbs	(kg)	3053	(1385)
Operating Weight	lbs	(kg)	3351	(1520)
Average axle load	lbs	(kg)	1675	(760)
Average static linear load CECE	pli	(kg/cm)	47.0	(8.4)

Dimensions

Working width	in	(mm)	35.4	(900)
Length with ROPS	in	(mm)	76.1	(1934)
Track Radius, inner	in	(mm)	77.6	(1970)
Dimensions	see sketch			

Driving Characteristics (depending on site conditions)

Speed (with vibration)	mph	(km/h)	0-2.8	(0-4.5)
Speed (for transport)	mph	(km/h)	0-5	(0-8)
Max. gradeability without/with vibration			40/30	

Drive

Engine manufacturer	Kubota		
Type	D 722 E3B		
Cooling - cylinders	water		
Number of cylinders	3		
Performance ISO 9249 (max)	hp	(kW)	16.6 (12.4)
Speed (max)	rpm	3000	
Electric Equipment	V	12	
Drive System	hydrostatic		
Drum Driven	front + rear		

Brakes

Service brake	hydrostatic
Parking brake	SAHR

Steering

Steering system	oscillating, articulating
Steering method	hydrostatic
Steering angle ±	31
Oscillating angle ±	6

Vibratory system

Vibrating drum	front + rear		
Drive system	hydrostatic		
Frequency	vpm	(Hz)	3600 (60)
Amplitude	in	(mm)	0.02 (0.5)
Centrifugal force (each drum)	lbs	(kN)	3600 (16)

Water Spray System

Type of water spray system	pressurized
----------------------------	-------------

Capacities

Fuel	gal	(l)	6.1	(23)
Water	gal	(l)	26.4	(100)

Technical modifications reserved. Machines may be shown with options.